

PLEASE READ THESE INSTRUCTIONS CAREFULLY BEFORE INSTALLATION.
PLEASE RETAIN INSTRUCTIONS FOR FUTURE REFERENCE.

Tradetec Eco Bay LED Low Bay Dimmable Light

PRODUCT FEATURES

- 5 year replacement warranty
- Die cast magnesium alloy heatsink
- Long life energy saving LED technology
- Dimmable - 3 in 1 dimming function (1~10Vdc, 10V PWM signal and resistance)
- Suitable for commercial spaces
- Reflector adaptable
- IP65 rated
- Mean Well driver

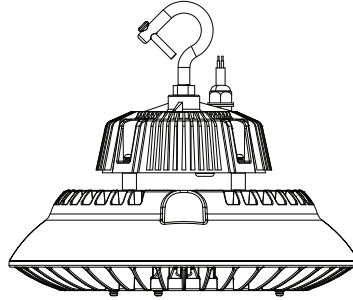

Optional Accessory - Aluminium Reflector

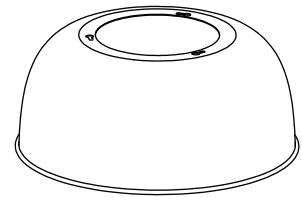

INSTALLATION (If reflector not purchased, move to Step 2)

1. Loosen protruding screws on LED Low Bay (Fig 1). Place aluminium reflector over protruding screws and twist to lock. Ensure reflector is secure then fasten protruding screws.
2. Carefully unpack the fixture from its packaging. Turn off the power to the appropriate circuit at the breaker panel.
3. Locate a stable structure to hang the fixture (Fig 2).
4. Mount fixture to the stable structure. Ensure fixture is within a reasonable distance of Junction box for wiring. Fasten the screw on the mounting hook to ensure safety.

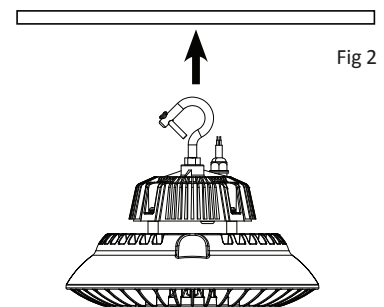
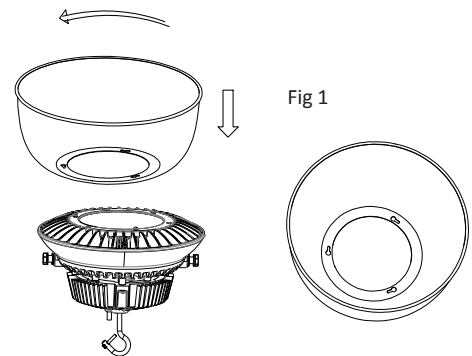

SAFETY

Installation of Tradetec Eco Bay's must follow S.A.A standards and meet local Authority regulations. A fully qualified and licensed electrician lawfully MUST carry out installation. Means for disconnection must be incorporated in the fixed wiring in accordance with wiring rules.

Tradetec Eco Bay MUST be earthed. Lowbay MUST be firmly attached to a solid structure.

COMPLIANCE

The Low Bay has been tested to comply with relevant Australian/New Zealand standards.

- AS/NZS 60598.2.1:2014
- AS/NZS 60598.1:2011
- SAA 162257

