

# Defender Tricolour COB LED Security Light CCT:3000k,4000k,5000k

Martec Pty Ltd 6 Austool Place Ingleburn, NSW2565  
 P: 02 8778 7500 F: 02 8778 7555  
 E: customerservice@martec.com.au

## DEFENDER Tricolour LED COB Security Light with CCT With & Without Sensor

### INTRODUCTION

Congratulations on purchasing your Martec high quality outdoor light fitting.

Model No.	Description	Tri Colour CCT	IP Rating	Warranty
MLDXD3451M	Single Spot	3000k, 4000k 5000k	IP54	2yrs
MLXD3451W	Single Spot	3000k, 4000k 5000k	IP54	2yrs
MLXLD3452M	Double Spot	3000k, 4000k 5000k	IP54	2yrs
MLXD3452W	Double Spot	3000k, 4000k 5000k	IP54	2yrs
MLXD3451MS	Single Spot with sensor	3000k, 4000k 5000k	IP54	2yrs
MLXD3451WS	Single Spot with sensor	3000k, 4000k 5000k	IP54	2yrs
MLXD3452MS	Double Spot with sensor	3000k, 4000k 5000k	IP54	2yrs
MLXD3452WS	Double Spot with sensor	3000k, 4000k 5000k	IP54	2yrs

LED Powered by Bridgelux COB 10Watt Per Head

Voltage: 220-240VAC-50/60Hz

For installation of your Defender CCT Tricolour outdoor LED spotlight, please refer to the Fig.1

1. Installation must be carried out by a licensed electrician and according to **AS/NZS 3000** and relevant amendments or warranty will be voided.
2. Switch power off at the meter box and ensure that there is no power to the lamp.
3. Unscrew the Front Cover Screws and then separate the light from the back plate.
4. Use the back plate to mark the position of the screw holes onto your mounting surface. Drill the wall to a depth of about 40mm and fit the wall plugs (supplied). Take care to avoid drilling or screwing into concealed electrical wiring.
5. Connect the Power Cable to the Terminal Block, see Fig.1, and ensure the cable is drilled through the Rubber Gasket (supplied) to maintain the fittings IP rating.
6. Affix the back plate to the mounting surface with the Mounting Wall Screws (supplied) once again using the Rubber Gasket (supplied) to maintain the fittings IP rating.
7. Re-fit the light fitting to the back plate mounted on the wall.

### Note:

Loosen knob on adjustable arm before making any adjustments to the direction and position of the light heads.

### INSTALLATION please read carefully

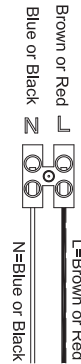

### Quick Connection System Easy Installation)

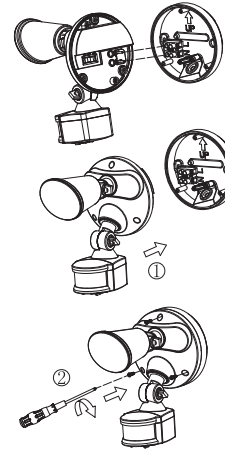

### OPERATING THE PASSIVE INFRARED SENSOR

MLXD3451WS	Single spot sensor	3000k, 4000k, 5000k	IP54
MLXD3451MS	Single spot sensor	3000k, 4000k, 5000k	IP54
MLXD3452MS	Double spot sensor	3000k, 4000k, 5000k	IP54
MLXD3452MS	Double spot sensor	3000k, 4000k, 5000k	IP54

When power is switched on to the Defender Sensor, it will enter into a "WARM-UP" period for approximately 50 seconds (within 1 minute) and then automatically change into "AUTO MODE". Whilst in the AUTO MODE, you can then carry out a Walk-Test by placing the LUX control to day position (.) and the TIME control to minimum (-). Once the sensor receives a valid trigger signal (such as movement of a human body) within its set distance detection area, the lamp(s) (load) will be turned on for the pre-set period of time.

You will be able to determine the detection area by walking slowly.

After completing the walk-test, set the LUX KNOB to the night position to ensure the sensor only operates at night and set TIME KNOB to the desired "ON" time.

### ADJUSTING THE LUX CONTROL LEVEL:

The Lux control module has a built-in sensing device (CdS photocell) that detects daylight and darkness. (•) position denotes that the lamp(s) (load) will be turned on by the PIR during both day and night. (▶) position denotes that the lamp(s) (load) will be turned on by the PIR only at night.

You can set to operate the unit at the desired level by adjusting the Lux Knob.

### ADJUSTING THE DURATION TIME:

The duration time is "the length of time that the sensor switches the load 'on' after activation". The duration time can be adjusted from (10±5) seconds to (4±1) adjustable minutes. Rotating the TIME knob from (+) to (-) will reduce the duration time.

Note: Once the lamp(s) (load) has been triggered by the PIR sensor any subsequent detection will start the timed period again from the beginning.

### How to change into MANUAL CONTROL MODE

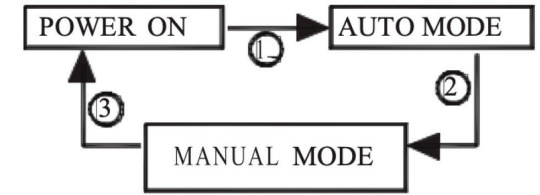

1. When the power is on, the PIR detector enters into the "WARM-UP" period for about 1 minute, then automatically changes into AUTO MODE.
2. During AUTO MODE, by switching the ON/OFF main switch 2 times within 3 seconds and then leaving the switch on, the PIR detector will automatically change into MANUAL MODE from AUTO MODE. In MANUAL MODE, the Lamp(s) will remain ON, in MANUAL MODE the PIR detector will not be affected by duration time and Lux control level.
3. During MANUAL MODE, by switching the ON/OFF main switch 2 times within 3 seconds then leaving the switch on, the PIR detector will automatically change into AUTO MODE from MANUAL MODE.
4. During MANUAL MODE or AUTO MODE, by switching off the ON/OFF main switch over 10 seconds and then on again, the PIR detector will reset to WARM-UP periods.

**Please note:** the period of "WARM-UP" maybe be shorter than 1 minute.

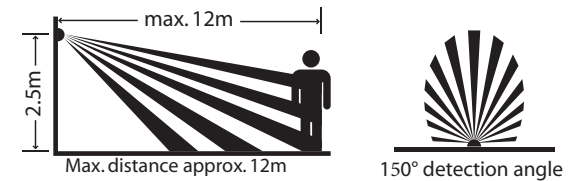

Fig.2 (A) DETECTION AREA

- a. The security lamp should be wired to its own light switch only. No two way switching. Do not interconnect with other lights on the same switch. Earth connection is be required.
- b. Ideally the security lamp should be mounted 1.8 to 2.5m (6 to 8ft) above the ground to be scanned (refer Fig.2A).
- c. To avoid damage to the sensor unit- DO NOT aim the sensor towards the sun or the photo electric cell will be damaged
- d. To avoid nuisance triggering, the sensor should be directed away from heat sources such as barbecues, Air-conditioners, other outside lighting, moving cars and flue vents.
- e. To avoid nuisance triggering, keeping away from areas of strong electromagnetic disturbance.



Fig.2(B) NOT GOOD



Fig.2(C) GOOD

f. Do not aim towards reflective surfaces such as smooth white walls, swimming pools, etc. The security lamp scanning specifications (approximately 12 metres at 150°) this may vary slightly depending on the mounting height and location. The detection range of the unit may also alter with temperature change. Before selecting a place to install your security lamp you should note that movement across the scan area is more effective than movement directly toward or away from the sensor (refer Fig. 2B). If movement is made walking directly towards or away from the sensor and not across, the apparent detection range will be substantially reduced. (refer Fig. 2C)

g. Take special caution to loosen lock nuts and screws on sensor before making any adjustments as this will not be covered by warranty.

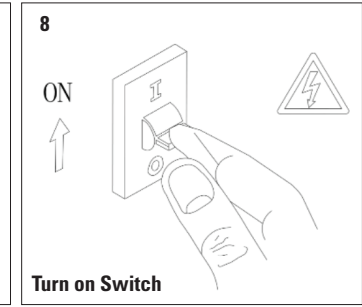
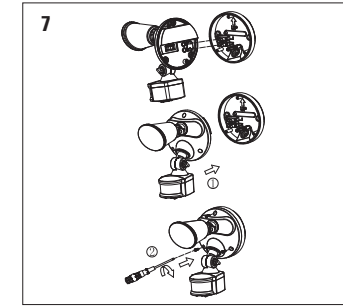
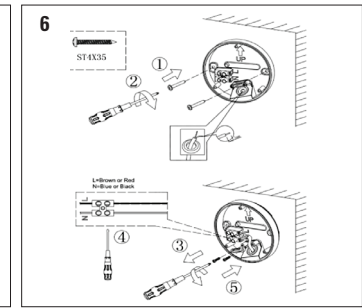
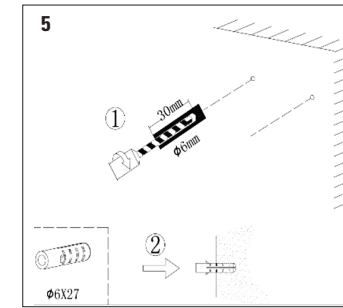

PROBLEM	POSSIBLE CAUSE	SUGGESTED REMEDY
Light does not switch on when there is movement in the detection area.	1. No mains voltage	Check all connections, and fuses/switches
	2. Nearby lighting is too bright	Re direct sensor or relocate the unit
	3. Controls set incorrectly	Re adjust sensor angle of control knob
	4. Sensor positioned in wrong direction	Re direct sensor and/or adjust
	5. Heat sources such as air-con, vents, heater flues, barbecues, other outside lighting, moving cars are activating sensor	Adjust direction of sensor head, away from these sources
	6. Animals/birds e.g. possums or domestic animals	Re directing sensor head may help
	7. Interference from on/off switching of electric fan or lights on the same circuit as your security light.(This problem does not always occur but a faulty switch may cause the Fortress to switch on.)	Should the false triggering become troublesome, consider: a. Relacing a faulty switch. b. Connecting the Defender to a separate circuit (in most cases where one or more of the above suggestions have) been carriedout, false triggering has been reduced.
	8. Reflection from swimming pool, or reflective surface.	Re direct sensor
Light remains on.	1. Continuously false triggered	Re directing sensor head may help
	2. Time is set too long	Reduce time
Light switches on during daylight hours	LUX control knob is set to daylight position	Turn the LUX control knob to desired light level setting
When setting controls in daylight the detection distance becomes shorter.	Interference by sunlight	Re-test at night

Note: All passive infrared detectors are more sensitive in cold weather than warm weather and more sensitive at night than daytime.

### DIAGRAM INSTRUCTIONS

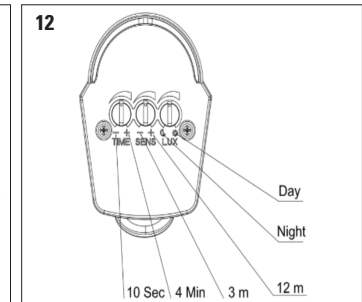
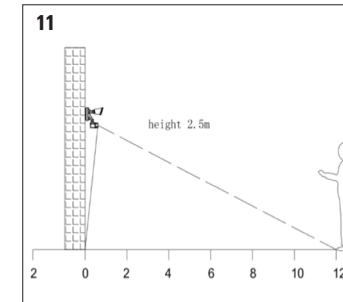
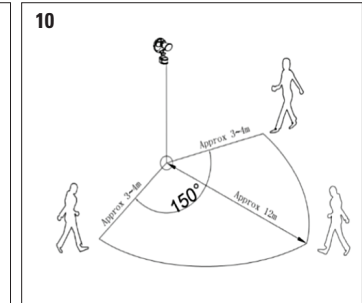
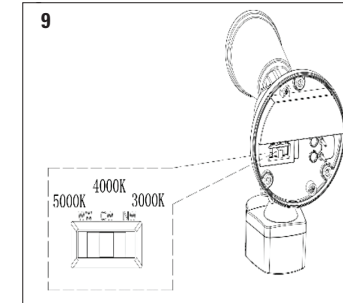
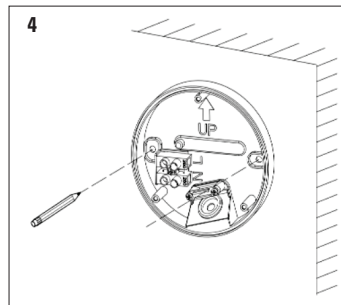
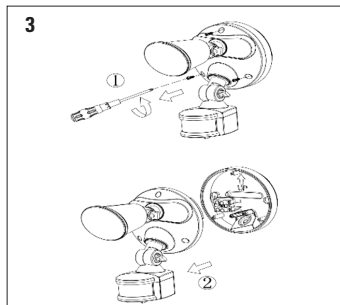
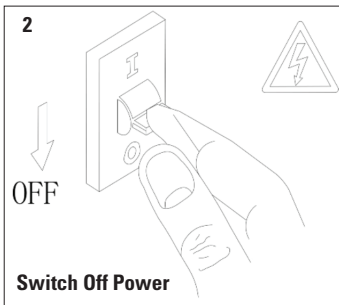
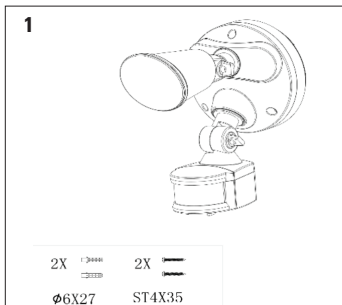

### CARE & CLEANING

- To avoid dust build-up and maintain proper performance, sensor lens to be cleaned lightly with a damp cloth every 3 to 6 months.
- Ensure fixture is turned off when cleaning.
- Do not use harsh abrasive or solvent on any surface part of this light fitting. Clean only using dilute mild detergent or damp cloth.
- The light source of this luminaire is not replaceable, when its end of life the whole luminaire will be required to be replaced, please dispose of the luminaire responsibly.